

7.0 电器/Electric Device

序号/ No.	名 称 / Designation	页 码 /Page No.
7,01	过电压报警装置/Over Voltage Alarming Device	1
7,02	09款电气控制系统(VDO)/Electric Control System(VDO)	2
7,03	09款HW7E载货车电器装置(ST双ZF、DE带取力器)/Truck electrical device	3
7,04	HW电气接线盒铭牌(英文)/Nameplate	5
7,05	145-320马力4*2/4*4底盘电器/Chassis Electric Device	6
7,06	240-320马力底盘电器/Chassis Electric Device	7
7,07	底盘电器/Chassis Electric Device	8
7,08	HOWO车前照灯/Headlamp	10
7,09	蓄电池(165安-时)/165 AH Battery	12
7,10	新型电瓶箱/Battery Box	13
7,11	轮、轴间差速锁电线(230)/Diff. Lock Wireness	14
7,12	车架电线束/Frame electrical harnesses	15
7,13	起动机负极至后分线盒搭铁线(1030)/Wiring harness	16
7,14	国2车型起动机附加电线束/Starter wiring harness	17
7,15	起动机电线束/Starter Wireness	18
7,16	HW7E自卸车底盘电线/Chassis Wireness	19
7,17	HW7E驾驶室电线束/Cab Wireness	20
7,18	尾灯电线/Rear Lamp Wireness	22

7.02 09款电气控制系统(VDO)/Electric Control System(VDO)

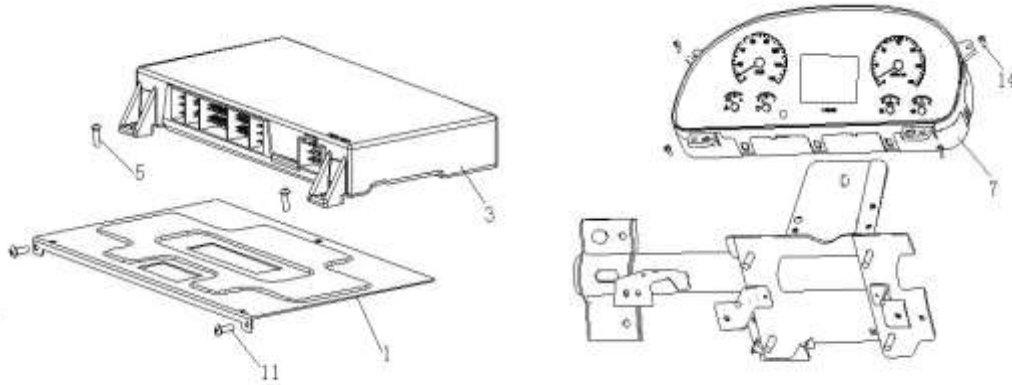

7.02 09款电气控制系统(VDO)/Electric Control System(VDO)

序号 No.	零部件图号 Part No.	名称	Part Name	数量 Qty	备注 Remark
1	AZ9724580002	CBCU安装板	CBCU Plate	1	
2	Q2714216	十字槽盘头自攻螺钉	Screw	2	
3	WG9716580023	中央控制单元 (CBCU)	CBCU	1	
5	Q2140512	十字槽盘头螺钉	Screw	3	
6	Q40105	平垫圈	Washer	3	
7	WG9716580025	组合仪表 (CMIC)	CMIC	1	
9	Q2714816	十字槽盘头自攻螺钉	Screw	4	
10	Q40105	平垫圈	Washer	4	
11	Q2714216F31	十字槽盘头自攻螺钉	Screw	2	
12	Q340B05	1型六角螺母	Nut	3	
13	Q340B05	1型六角螺母	Nut	3	
14	Q2714816F31	十字槽盘头自攻螺钉	Screw	4	

7.03 09款HW7E载货车电器装置 (ST双 ZF、DE带取力器) /Truck electrical device

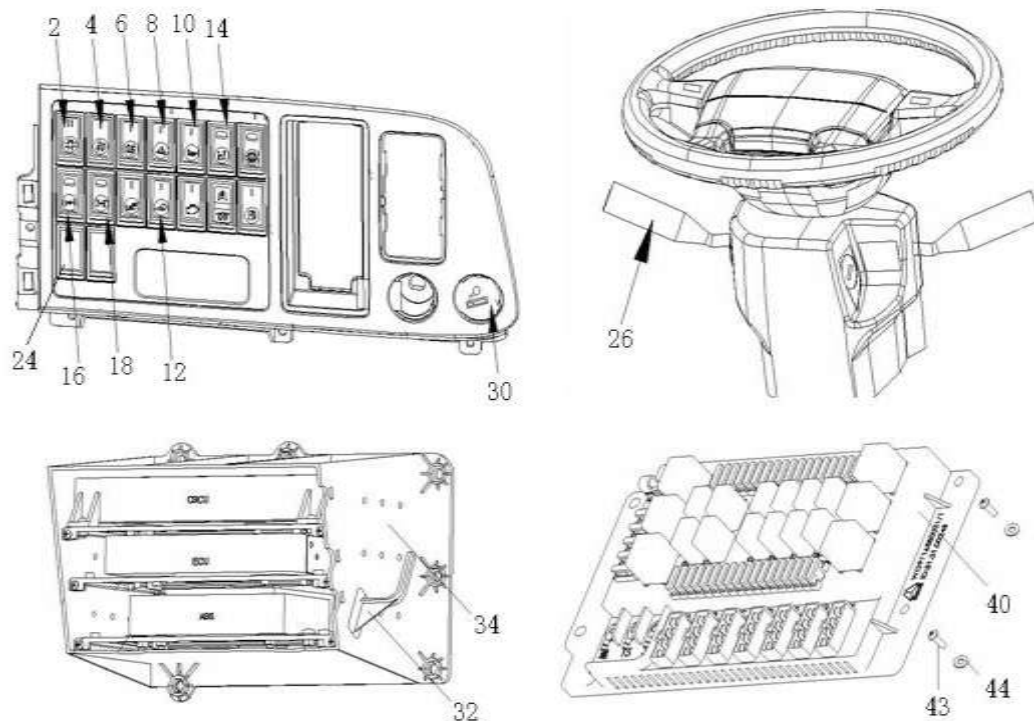

7.03 09款HW7E载货车电器装置 (ST双 ZF、DE带取力器) /Truck electrical device

序号	零部件图号	名称	Part Name	数量	备注
No.	Part No.			Qty	Remark
2	WG9719584011	灯光开关	Lighting switch	1	
4	WG9719584012	前雾灯开关	Switch	1	
6	WG9719584013	后雾灯开关	Switch	1	
8	WG9719584004	危急报警开关	Hazard switch	1	
10	WG9719584015	喇叭开关	Switch	1	
14	WG9719582010	取力器开关	Switch	1	
16	WG9719582011	轮差开关	Switch	1	
18	WG9719582012	轴差开关	Switch	1	
20	WG9725580005	诊断接口外壳	Cover	1	
22	WG9719582054	MCS旋钮	MCS knob	1	
24	WG9900580021	盖板	Cover	6	
26	WG9130583117	组合开关(转向柱上)	Multi-function switch	1	
30	WG9100580142	24V点烟器	Cigar lighter	1	
32	WG9725584026	线束固定夹	Clip	1	

34	WG9725584029	ECU安装箱	Box	1	
40	WG9716580021	电气接线盒总成	Case assembly	1	
41	WG9719582056	发动机制动开关	Switch	1	
43	Q2140635	盘头螺钉	Screw	4	
44	Q40106	平垫圈	Washer	5	
51	Q2140512	十字槽盘头螺钉	Screw	3	

7.03 09款HW7E载货车电器装置 (ST双 ZF、DE带取力器) /Truck electrical device

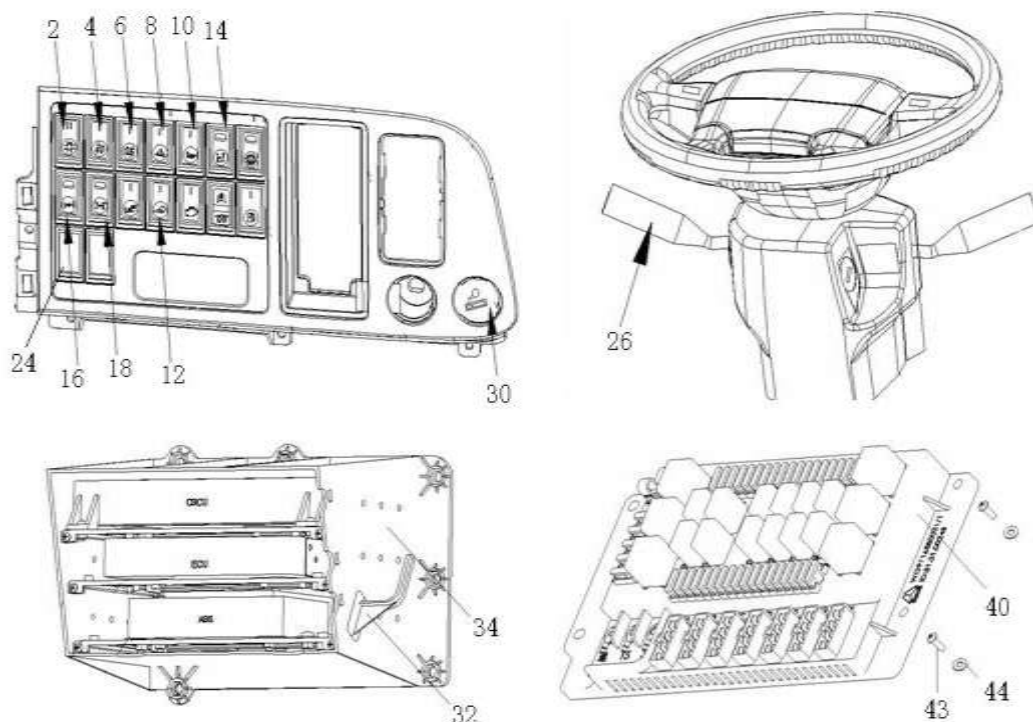

7.03 09款HW7E载货车电器装置 (ST双 ZF、DE带取力器) /Truck electrical device

序号	零部件图号	名称	Part Name	数量	备注
No.	Part No.			Qty	Remark
52	AZ9725580030	橡胶堵盖	Plug	1	
60	Q150B0825	六角头螺栓	Bolt	5	
61	Q40108	平垫圈	Washer	5	
62	Q40308	弹簧垫圈	Spring washer	5	
63	Q340B08	1型六角螺母	Nut	5	
76	Q2140610	十字槽盘头螺钉	Screw	1	
77	Q2140510	十字槽盘头螺钉	Screw	2	
78	Q40105	平垫圈	Washer	2	
79	WG9725584001	40A常开式继电器	Relay-40A	3	
83	WG9725584002	20A常开式继电器	Relay-20A	10	

8	WG9725710004	支架	Bracket	1	
10	Q2140620F31	十字槽盘头螺钉	Screw	2	
11	Q40306	弹簧垫圈	Spring washer	2	
12	WG9727710002	电子式气压传感器	Air pressure sensor	2	
14	WG9719710004	电磁阀 (P99接头)	Solenoid valve	4	
16	Q150B0875	六角头螺栓	Screw	2	
17	Q150B08190	六角头螺栓	Screw	2	
18	Q40308	弹簧垫圈	Spring washer	4	
19	Q340B08	I型六角螺母	Nut	4	
20	WG9725584002	20A常开式继电器	20A relay (normally on)	1	
22	Q2140410	十字槽盘头螺钉	Screw	1	
25	WG9725580086	铅封	lead sealing	1	
27	190000810930	铅封线	lead sealing	40CM	
28	WG9725580006	100A保险装置	100A fuse	1	
31	Q150B0620	六角头螺栓	Screw	2	
32	Q40306	弹簧垫圈	Spring washer	2	

7.07 底盘电器/Chassis Electric Device



7.07 底盘电器/Chassis Electric Device

序号	零部件图号	名称	Part Name	数量	备注
No.	Part No.			Qty	Remark
33	Q40106	平垫圈	Washer	2	
34	Q340B06	I型六角螺母	Nut	2	

1	WG9719720001	左前照灯总成	Headlamp ass. -left	1	
4	WG9719720002	右前照灯总成	Headlamp ass. -right	1	
4a	Q150B0822	六角头螺栓	Screw	2	
4b	Q150B0816	六角头螺栓	Screw	2	
4c	Q340B08	I型六角螺母	Nut	4	
4d	Q40108	平垫圈	Washer	8	
4e	Q40308	弹簧垫圈	Spring washer	4	
4f	Q2140620	十字槽盘头螺钉	Screw	4	
4g	Q40106	平垫圈	Washer	4	
4h	Q40306	弹簧垫圈	Spring washer	4	
6	AZ9718720002	前照灯安装板	Plate	2	
6a	Q150B0820	六角头螺栓	Screw	6	
6b	Q40308	弹簧垫圈	Spring washer	6	
8	AZ9718720003	连接板	Plate	2	
8a	Q150B0616	六角头螺栓	Screw	4	
8b	Q340B06	I型六角螺母	Nut	4	
8c	Q40106	平垫圈	Washer	4	
8d	Q40306	弹簧垫圈	Spring washer	4	
8e	Q40108	平垫圈	Washer	6	
8f	Q40308	弹簧垫圈	Spring washer	6	

7.08 HOWO车前照灯/Headlamp

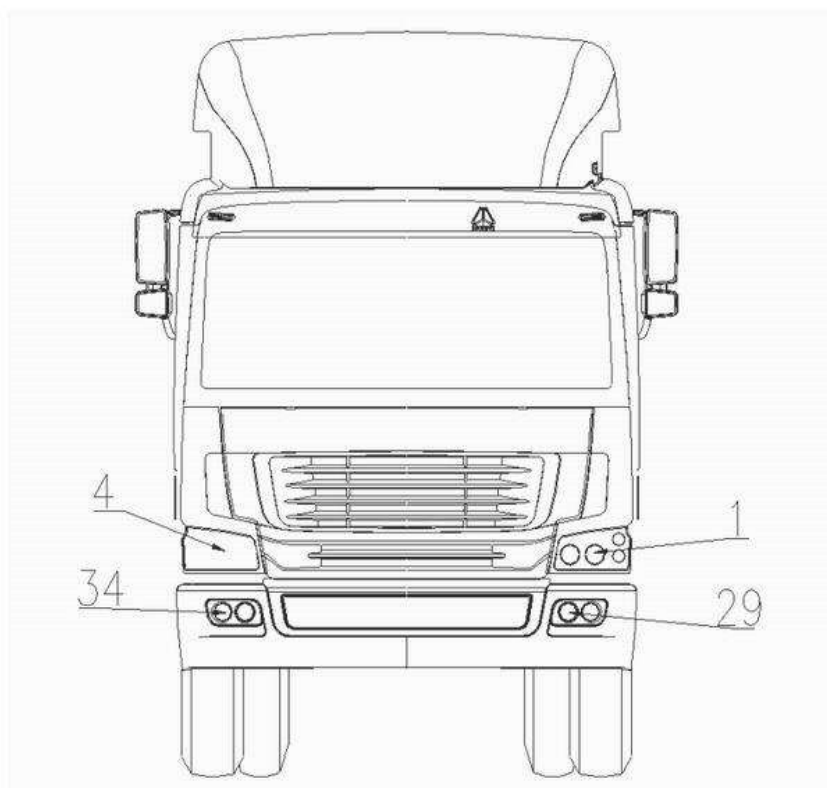

7.08 HOWO车前照灯/Headlamp



Forward

Frame

7.10 新型电瓶箱/Battery Box

序号	零部件图号	名称	Part Name	数量	备注
No.	Part No.			Qty	Remark
1	AZ9725760005	HOWO电瓶箱体总成	Battery Box	1	
1,1	AZ9100760110	电瓶箱锁总成	Lock ass.	2	
1,2	AZ9725760003	HOWO电瓶箱体总成	Battery Box	1	
6	Q151B1645	六角头螺栓	Screw	4	
7	Q151B1650	六角头螺栓	Screw	4	
8	190003888459	自锁螺母	Nut	8	
9	AZ9100760102	电瓶箱盖	Battery box cover	1	
10	AZ9100760104	压板	Plate	2	
11	Q340B08	1型六角螺母	Nut	6	
12	Q40208	大垫圈	Washer	6	
13	Q40308	弹簧垫圈	Spring washer	6	
14	1682 110021	橡胶缓冲块	Rubber cussion	6	
15	AZ9100760108	下橡胶垫板	Rubber cussion	1	
16	WG9100760100	电源总开关	Main switch	1	
18	199100760099	密封垫	Gasket	1	
23	AZ9719770058	橡胶过孔护圈 (Φ50/Φ3)	Rubber ring	2	
24	Q150B0620	六角头螺栓	Screw	2	
26	AZ9925760004	电器连接板	Plate	1	
27	Q150B0814	六角头螺栓	Screw	4	
28	Q33208	锁紧螺母	Nut	4	

7.11 轮、轴间差速锁电线 (230) /Diff. Lock Wireness



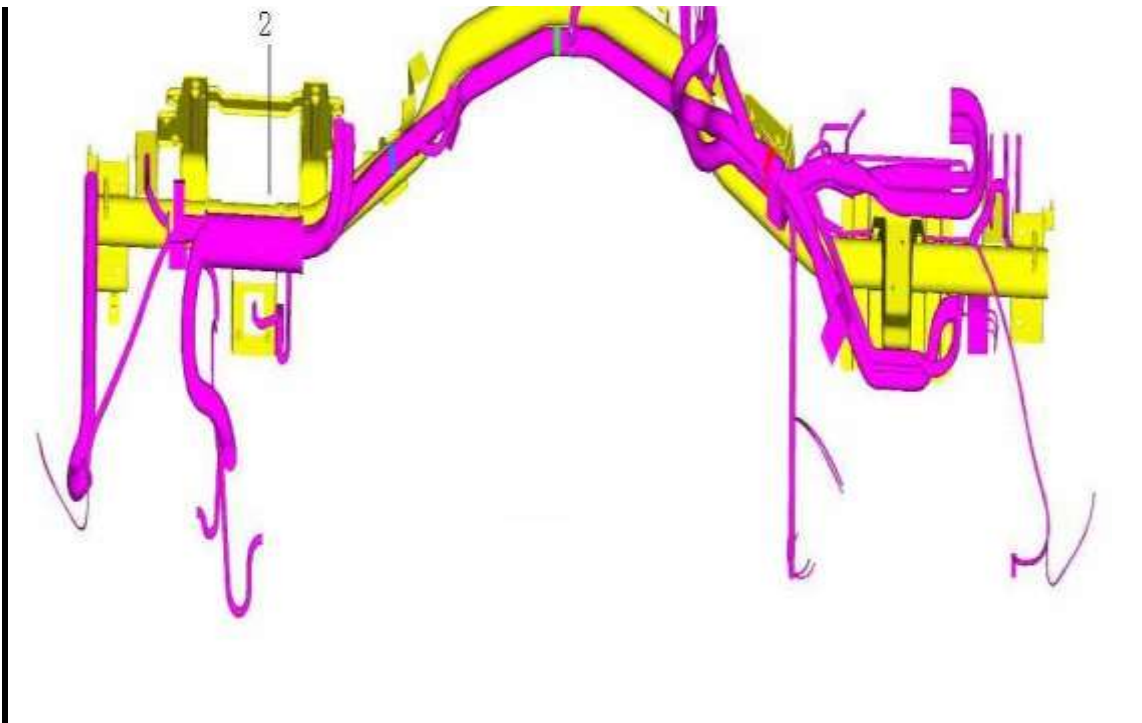

7.17 HW7E驾驶室电线束/Cab Wireness

序号	零部件图号	名称	Part Name	数量	备注
No.	Part No.			Qty	Remark
2	AZ9721770101	HW7E驾驶室电线束	Cab wireness	1	
3	Q41205	外锯齿锁紧垫圈	Washer	3	
4	Q68620	单管夹片	Clip	1	
5	Q150B0616	六角头螺栓	Screw	1	
6	Q40306	弹簧垫圈	Spring washer	1	
7	Q340B06	I型六角螺母	Nut	1	
8	WG1642110018	保护条	Strip	10	
9	WG9725584005	120Ω电阻	120Ω Resistance	2	
10	WG9725584031	过线盒体	Box	1	
11	Q2140825	十字槽盘头螺钉	Screw	4	
12	Q340B08	I型六角螺母	Nut	4	
13	Q40108	平垫圈	Washer	8	
14	Q40308	弹簧垫圈	Spring washer	4	
15	WG9725584032	过线盒盖	cover	1	
16	Q2140420	十字槽盘头螺钉	Screw	4	
17	AZ9719770047	橡胶过孔护圈 (Φ50)	Protect ring	1	
18	WG9100770392	分线盒体	Distributing box	1	
19	179100770391	配电盒	Distributing box	1	
20	179100770387-1	连接片(11线)	Connect piece	1	
21	179100770388-1	连接片(5线) 见0387	Connect piece	2	

7.17 HW7E驾驶室电线束/Cab Wireness

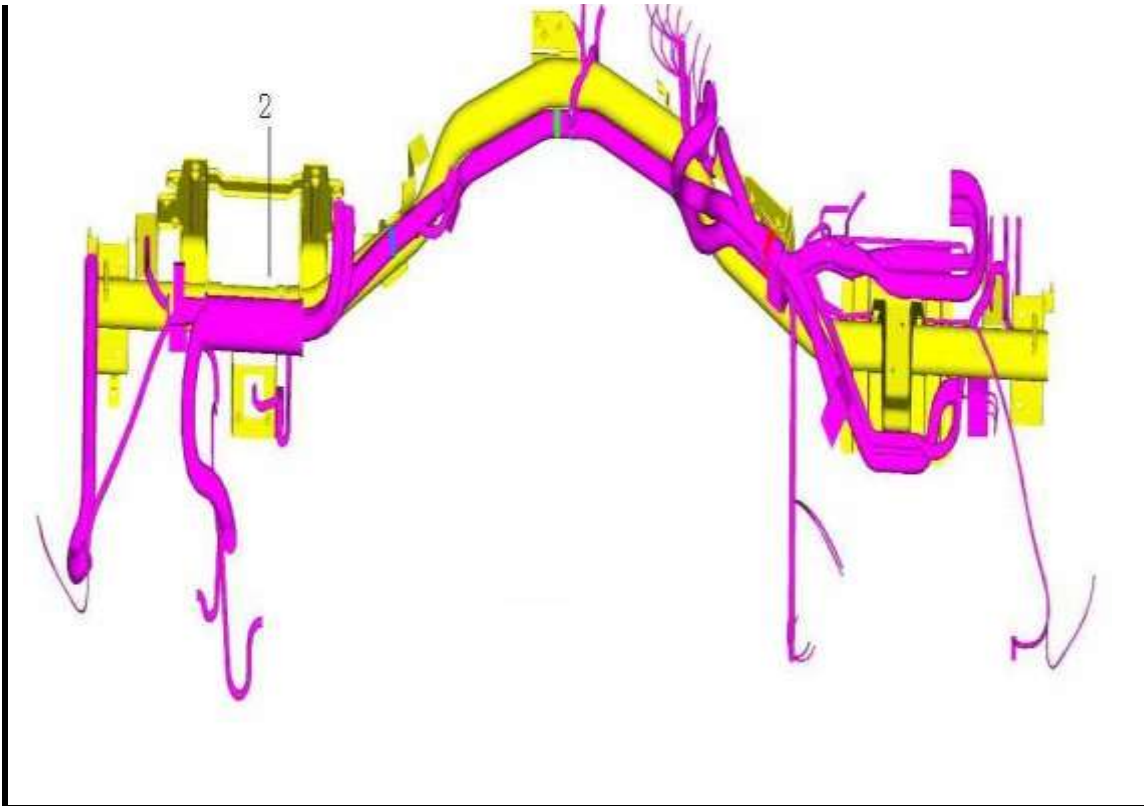

7.17 HW7E驾驶室电线束/Cab Wireness

序号 No.	零部件图号 Part No.	名称	Part Name	数量 Qty	备注 Remark
22	179100770389-1	连接片(3线) 见0387	Connect piece	4	
23	179100770414-1	连接片(4线) 见0387	Connect piece	2	
24	179100770415-1	连接片(6线) 见0387	Connect piece	1	
25	179100770416-1	连接片(8线) 见0387	Connect piece	1	
26	Q2762995	开槽半沉头自攻螺钉	Screw	3	
27	WG9100770394	分线盒盖	Distributing box cover	1	
28	179100770395	电线护套	Protect sleeve	4	
29	190003120032	园形密封条	Sealing	570mm	
30	Q2713525	十字槽盘头自攻螺钉	Screw	4	
31	Q150B0630Q	六角头螺栓	Screw	2	
32	Q40306	弹簧垫圈	Spring washer	2	
33	Q340B06	I型六角螺母	Nut	2	
34	190003171356	塑料紧固带	Fastener	15	
35	190003171392	塑料紧固带	Fastener	15	
36	WG9725584025	2.7kΩ 电阻	2.7kΩ Resistance	2	

7.18 尾灯电线/Rear Lamp Wireness

--	--	--	--	--	--